

Hydraulische machine heffers / Hydraulic toe jacks / Hidraulinis domkratas su kojele

Tel.+370 676 65626 , bagra@bagra.lt

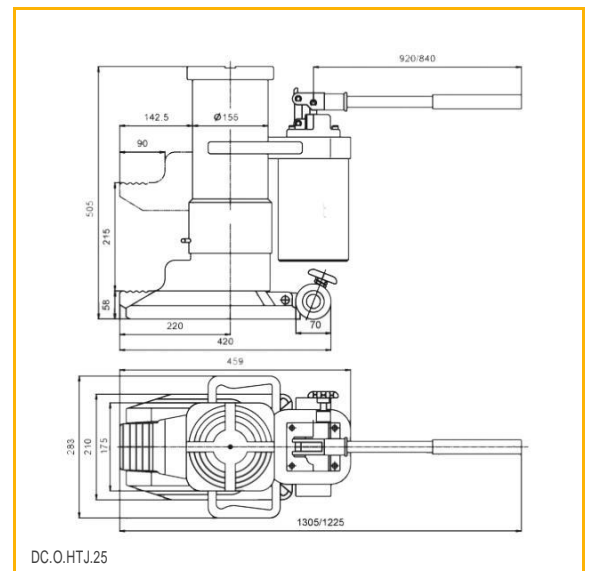
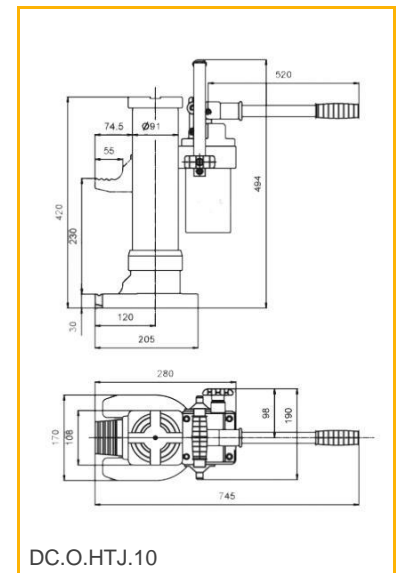
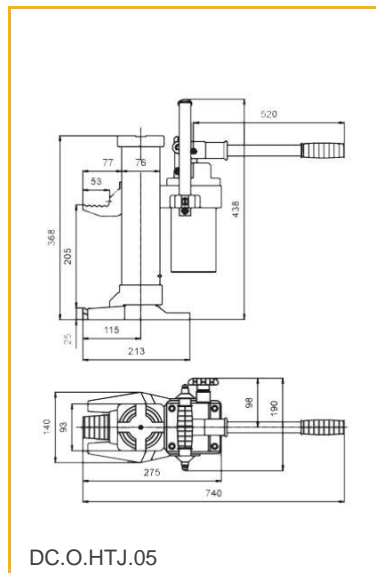
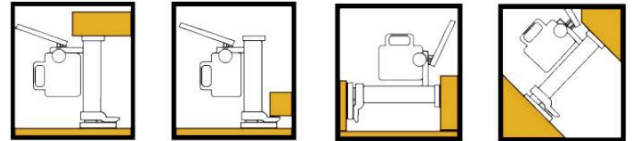

**Eigenschappen**

- » Compact en zeer stabiel.
- » Te gebruiken in iedere positie.
- » Huis 360° draaibaar.
- » Gecontroleerd zakken.
- » Met overlastbeveiliging.
- » Afneembare hevel.

**Features**

- » Compact and stable construction
- » Can be used in any position.
- » Housing revolves 360°.
- » Lowering speed can be accurately adjusted.
- » With overload protection.
- » Pump lever is removable.

Model	Specificaties / Specifications				
	Capaciteit Capacity	Hefbereik van voet Lifting range of foot	Hefbereik van kop Lifting range of head	Inspanning voor max lading Force for max lifting	Netto gewicht Net weight
	ton	mm	mm	N	kg
DC.O.HTJ.05	5	25-230	368-573	280	25
DC.O.HTJ.10	10	30-260	420-650	400	35
DC.O.HTJ.25	25	58-273	505-720	400	109



Elévateurs de machine / Hydraulische Heber

Tel.+370 676 65626 , bagra@bagra.lt

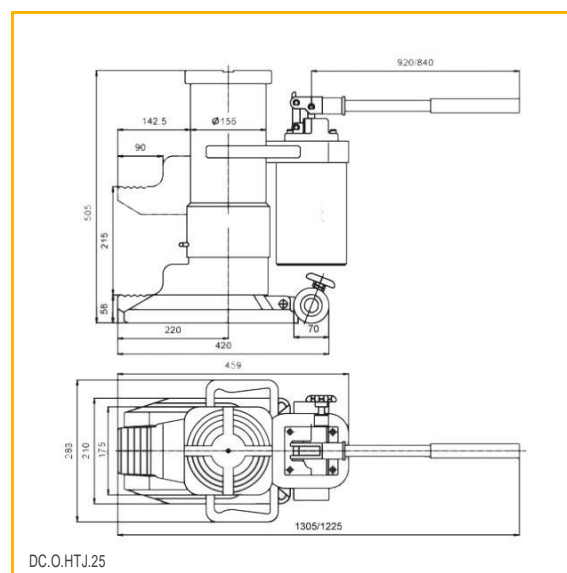
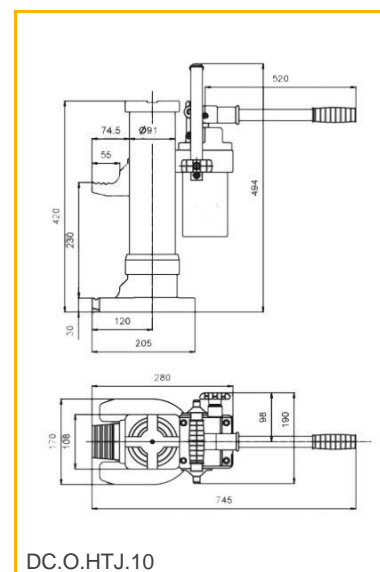
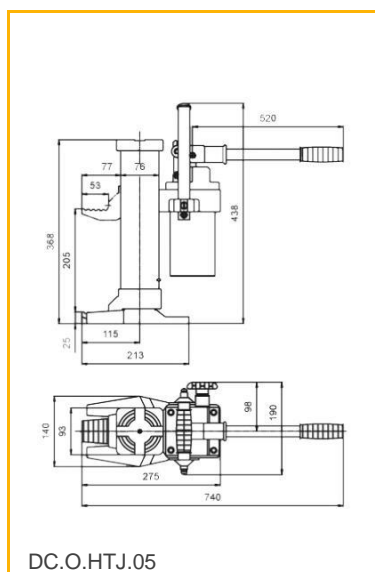
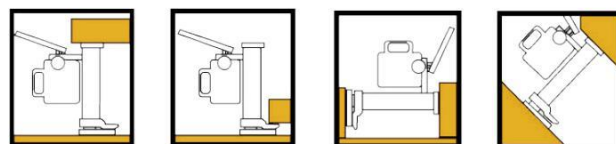

**Caractéristiques**

- » Compact et très stable.
- » A utiliser dans chaque position.
- » Boîtier tournable à 360°.
- » Descente contrôlée.
- » Avec protection de surcharge.
- » Levier de pompe amovible.

**Eigenschaften**

- » Kompakte und stabile Bauweise.
- » Kann in jeder Position benutzt werden.
- » Gehäuse ist um 360° drehbar.
- » Senkgeschwindigkeit kann genau eingestellt werden.
- » Mit Überlastungsschutz.
- » Abnehmbarer Hebel.

Spécifications / Spezifikationen					
Modèle	Capacité	Gamme de pieds de levage	Gamme de coupe de levage	Effort pour chargement max	Poids net
Modell	Kapazität	Hubbereich Fuß	Hubbereich Kopf	Kraft für max Last	Netto Gewicht
	ton	mm	mm	N	kg
DC.O.HTJ.05	5	25-230	368-573	280	25
DC.O.HTJ.10	10	30-260	420-650	400	35
DC.O.HTJ.25	25	58-273	505-720	400	109